



**Evergreen North America**  
INDUSTRIAL SERVICES



**GEM**  
AN EVERGREEN NORTH AMERICA COMPANY

**Count on  
Evergreen North America  
to be your single  
source provider.**





## Count on Evergreen North America to be your single source provider.

The specialized industrial and environmental services provided by Evergreen North America are the highest-quality available today.

Whether you require services for large-scale industrial outages or field services smaller in scope, Evergreen North America believes that the approach to any project must be safe, environmentally sound and cost effective.

Our comprehensive knowledge, engineered solutions and results oriented approach has earned us our reputation for excellence in the industry.

Evergreen North America's single source concept is exemplified by seamless coordination between all core and specialty services and divisions.

Investing heavily in the latest engineered technology and training, with a commitment to safety and professionalism, Evergreen North America can simultaneously maintain a superior level of quality, cut project costs and eliminate your need to deal with multiple vendors.



# Evergreen North America

INDUSTRIAL SERVICES

# GEM

AN EVERGREEN NORTH AMERICA COMPANY

# HYDRO-BLASTING SERVICES

## High Pressure cleaning using the latest Technology

Evergreen North America's trained and certified technicians utilizing the newest advances in technology have made this proven method even better. Evergreen North America continually invests in this state-of-the-art equipment and our technicians are equipped with a full range of hydroblasting tools to complete your job as quickly and efficiently as possible. Using the latest automated equipment, we can shorten your downtime and provide the application best suited to your cleaning requirements.

Our automated technology also improves safety during the project by eliminating the fatigue factor that results from hours of operating manual cleaning equipment.

- Cleaning pressures up to 40,000 psi or up to 200 GPM
- Allows several rotary or 3D nozzles to run simultaneously
- Remote-operated multi-tube lance machines
- High-volume automated shell side cleaning equipment
- Online slag removal
- Reduced downtime during cleaning
- Increased productivity resulting from cleaned equipment
- Improved safety
- More efficient scheduling and slab management

# ULTRA HIGH-PRESSURE WATER CUTTING

Whether you have a job as complex as cutting towers for removal, or as simple as flange prep, ultra-high-pressure water cutting services will get it done.

Our highly trained professionals have the expertise to assess, plan and complete your job in the most efficient and cost-effective way. They come equipped with the latest technology and years of experience in the field.

- Mobile UHP unit with all tools on board
- 40,000 psi cutting or cleaning pressure
- Project management experience averaging more than 15 years
- Reliable equipment to reduce downtime
- Over 450 jobs completed since 2003 under budget and/or ahead of schedule



# HYDRO-BLASTING AUTOMATION/REMOTELY OPERATED

- Product line specific project management and development team
- Job specific engineering
  - Process controls on feed and rotation rates
  - Increased horsepower and flow rates
- Reduced risk
  - Remove human element from line of fire
  - Reduce fatigue factor
- Advanced equipment designs provide ease of set up and functional flexibility
- Water recirculation systems and hydraulic dump system to reduce waste

Cleaning pressures from 10,000 psi up to 40,000 psi

## **Pump sizes:**

- 10k/20k – 200, 300, 425, 600, 705 HP
- 40k – 200, 300, 425, 600, 705 HP
- Operated automated hands-free tooling, multiple tube lancing, shell side cleaning equipment

Efficient scheduling and slab management

## **Capabilities:**

- 2L multi flex lancing
- Multi lance stiff lancing machine
- Navigator small bore line moling
- Rotary hose device large bore line moling
- Micro arm automated shotgunning capabilities
- 2D high volume shell and vessel cleaning
- 3D high volume tower and vessel cleaning
- Specialized water cutting
- ATL 5000 cabover and remote operated
- High volume shell side units
- Ultra high-volume pumps
- Mini X shotgunning
- Custom slab designs
- Water recirculation unit



# CHEMICAL CLEANING

## In-Place Cleaning Customized for Your Process Equipment

Evergreen North America provides state-of-the-art chemical cleaning, removing deposits with proprietary formulations, handling the most difficult cleaning challenges. Samples of deposits are gathered and lab tested to determine the most effective cleaning method.

Your Evergreen North America project manager will consider all factors such as system metallurgy, flow rates, degree of fouling and operational parameters. Using a wide range of selective chemistry including alkalis, acids, inhibitors, wetting agents, sequestrants and organic solvents, we'll choose the optimal chemical formulation for your job.

- Safer, quicker, and more economical than equipment disassembly
- Quality cleaning with modern equipment
- Experienced supervisors and technicians
- Easy, effective solution to any fouling problem
- Proprietary specialty chemical formulas and delivery systems
- Onsite potable lab

### **Evergreen North America offers state of the art equipment with proven methods and procedures.**

- Petroleum refining and petrochemical  
Petroleum midstream, pipeline and terminals
- Utility power generation
- Cogeneration industry
- Food and beverage industry
- Pulp and paper industry
- Aerospace industry
- Mining industry



# TANK CLEANING AND WASTE MINIMIZATION

## Safe, Reliable, Efficient Solutions for Turnkey Tank Cleaning

Maximizing the value of tank cleaning means minimizing costs, downtime, risk and residual waste. To make it happen, Evergreen North America offers a complete suite of turnkey services – from extensive project planning and engineering to centrifuge setup, robotic sludge removal, solid waste management, transportation, degassing and vapor recovery.

### A Unique Resource

Evergreen North America efficiently handles small, routine jobs as well as complex, high-volume projects in tanks up to 340 feet in diameter. Our experience includes virtually every tank design and type of material: crude, finished products, petrochemical feedstocks, black oil, asphalt, waste water, sour water and more. Evergreen North America is the contractor of choice for the most difficult tank cleaning projects, including jobs where other contractors have failed.

- High sludge levels
- Limited access to material
- Strict requirements for recovered projects
- Hazards such as benzene, volatile hydrocarbons, hydrogen sulfide, and radioactive sludge
- Damaged tanks

Unlike many service companies, Evergreen North America has a division dedicated to tank cleaning. Personnel are highly trained, experienced, and focused exclusively on cleaning and waste minimization. As a result, Evergreen North America delivers a higher level of responsiveness, efficiency, safety and environmental compliance.

### Benefits

- Turnkey service
- Cost efficiency
- Stringent environmental compliance
- Rapid turnaround
- Risk minimization

### Cleaning Technology

Evergreen North America offers the latest, most advanced non-entry cleaning technology to protect personnel, control emissions, and increase productivity. Included are automated processes and robotic systems that operate while the tank remains sealed. These devices spray diesel fuel or any other readily available diluent to wash interior surfaces and liquefy sludge for removal. Liquefied material is heated to improve pumpability and drawn out of the tank for processing.



Robotic systems include manway cannons, drop leg nozzles and robotic crawlers, as well as valve-controlled shell lances. Access can be gained through any available roof or side manway. Devices are controlled by specialists in on-site command centers located a safe distance from the tank. The variety of devices and techniques available allows Evergreen North America to customize procedures for each project to save time, improve productivity and meet unique requirements.

## On-site Processing

Depending on customer requirements, material from the tank is often processed on-site to minimize waste and reduce disposal costs. Evergreen North America offers a variety of processing techniques. Belt presses and filter presses are used to dewater aqueous sludges, while high-volume decanter centrifuges are employed for oily sludges.

High-speed centrifuges used by Evergreen North America generate force 2,000 times greater than gravity to separate solids and liquids at a molecular level. The result is exceptionally dry waste for disposal and clarified effluent ready for reuse.

Although other service companies use centrifuges, Evergreen North America specialists have a level of expertise that yields exceptional results – keeping waste management, transportation and disposal costs to a minimum.

## Safety and the Environment

The hazardous nature of tank cleaning demands the most stringent standards for safety. For Evergreen North America, safety begins with pre-project planning that includes hazard mitigation steps and continues with API-certified tank entry supervisors, rigorous daily Job Safety Analysis requirements and more. Crew members are trained according to the highest industry standards, including 40-hour HAZWOPER and OSHA training.

Evergreen North America has an award-winning safety record, including NPRA Contractor Merit Awards, Industrial Safety Training Council Awards, and OSHA Voluntary Protection Programs (VPP) Star status. Evergreen North America also keeps environmental protection at the forefront of operations. Containment procedures and strict job site housekeeping prevent accidental spills. Effective material processing not only reduces waste, but also makes liquid components available for re-use by the plant. Vapor-tight tank cleaning controls emissions, while all degassing and vapor recovery services meet or exceed the local, state and federal regulations.

For a higher level of responsiveness, reliability and cost efficiency plus uncompromising safety and environmental protection contact Evergreen North America today.



## VACUUM TRUCK SERVICES

Whatever your requirements for industrial vacuuming, Evergreen North America can provide the right equipment and personnel to do your project on time and on budget. With highly trained machine operators and state-of-the-art equipment, we bring the best team to your site to get the job done efficiently.

Our full complement of vacuuming equipment includes liquid vacuum units, air machines, hydro- excavation jet rodder and Myers cleaning systems. In-line hydrocarbon scrubbers and pressure relief tools ensure a high level of safety.

### Liquid Vacuum Units

- 70-Barrel hatchback, 3,000-gallon capacity
- 130-Barrel vacuum tanker, 5500-gallon capacity, for liquid and slurry materials
- DOT Certified for over-the-road hauling
- Scrubber system available with 99% vapor removal efficiency

### Air Machine Units

- 16-Cubic-yard debris box
- 27-inch Mercury vacuum (maximum)
- 5500-SCFM Maximum airflow, for heavy sludge and solids
- Two-stage filtration to eliminate dust
- Cyclone attachments
- Auger attachments

## PIPELINE CLEANING

### JUST LIKE NEW AGAIN

It has been demonstrated again and again that a pipeline cleaned by the Evergreen North America process will have the flow characteristics equal to what it had when the pipeline was first commissioned. This is possible because the design of the Evergreen North America cleaning tool is such that the cutting blades work without gouging or scraping the inner pipe wall.

### INDUSTRIES SERVED INCLUDE:

- Refineries
- Mining Operations
- Chemical Plants
- Power Plants
- Aluminum Manufacturing
- Paper Mill
- Municipal Water
- Steel
- Cast Iron
- Concrete
- PVC
- Lined Pipes





# ABRASIVE BLASTING & SURFACE PREPARATION

Abrasive blasting is achieved by propelling an abrasive media through an adjustable nozzle at high velocity. Evergreen North America's abrasive blasting technicians have utilized this technology in a variety of instances. The most common include surface preparation, electrostatic precipitator cleaning, inspection prep, cleaning and resurfacing. We can utilize 40,000 cfm portable dust collectors during the grit operations.

## MULTIPLE CAPABILITIES

Evergreen North America's blasting techniques, along with its large selection of blasting media can meet virtually any project specification. From single to multiple nozzle applications, Evergreen North America offers project tailored solutions that save you time and money.

## MAXIMUM CAPACITY AND MOBILITY

- Utilize mobile grit rigs
- Travel to job sites throughout the country
- Equipped with blasting pots
- Hold from 500 pounds to over six tons of blasting media
- Run at high capacity for extended periods
- Unmatched efficiency

## ABRASIVE BLASTING APPLICATIONS:

- Boilers, Vessels and Tanks
- Electrostatic Precipitators
- Wastewater Treatment Components
- Tanks and Silos
- Structural Steel
- Bag-houses and Ducts
- Piping
- Hoppers
- Buildings and Bridges
- Rail Cars
- Ships

## TYPES OF BLAST ABRASIVES:

- |                  |               |                   |
|------------------|---------------|-------------------|
| • Black Beauty   | • Baking Soda | • Starblast       |
| • Copper Slag    | • Garnet      | • Magnesium Oxide |
| • Aluminum Oxide | • Corn Cob    | • Walnut Shell    |

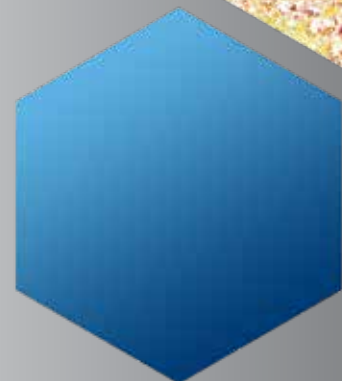

# DRY ICE BLASTING

Dry ice blasting is suitable for both aggressive and delicate cleaning challenges. This enables us to service numerous types of dry ice blasting applications. Dry ice cleaning provides a completely non-abrasive method that does not damage or etch equipment, even delicate circuit boards, which will allow your machinery to maintain its integrity. Dry ice blasting services does not require equipment disassembly, which will save on both expenses and downtime. You do not need to move your equipment prior to cleaning, which expedites cleaning time and prevents potential damage from occurring.

## BENEFITS:

- Non-conductive and "dry" cleaning approach
- No secondary waste stream
- No dry out period
- Will not damage electric motors
- Non-toxic cleaning approach
- Safe for the environment
- Safe for personnel

## INDUSTRIES:

- Automotive
- Manufacturing
- Food Manufacturing and Processing
- General Plant Maintenance
- Marine and Boat
- Plastics Manufacturing
- Energy
- Ethanol and Refinery
- Printing and Packaging
- Wine and Beverage Processing
- Fire Restoration, Mold and Historic Preservation
- Foundries
- Textile Industry
- Rotor Cleaning
- Cleaning
- Steam Generator Cleaning

Pioneered boiler and stack coil cleaning in the ethanol industry in 2007. This process has saved the industry nearly \$20 million dollars in natural gas since then.



**BEFORE**



**AFTER**



# FUGITIVE DUST REMEDIATION/ FOAM CLEANING

Evergreen North America utilizes a specifically designed foaming agent that encapsulates dust and safely removes the dust from the wall, ceilings, girders, framework and other areas. The foaming agent encapsulates the dust and carries down to low-lying areas. The foam then dissipates allowing the remnants to be either swept away or safely vacuumed up.

## THIS PROCESS IS IDEAL FOR REMOVING DUST IN VARIOUS INDUSTRIES INCLUDING BUT NOT LIMITED TO THE FOLLOWING:

- Coal Dust (Including PRB)
- Plastic Dust
- Paper Dust and Fibers
- Carbon Dust
- Foundry
- Fly Ash
- Regular Industry Dust
- Cob Webs
- Grain Dust
- Power Plants
- Chemical Manufacturing
- Agricultural
- Rubber Manufacturing
- Refineries

## Benefits:

- OSHA and NFPA compliant
- Portable
- Safely removes combustible, explosive and fugitive dust
- Reduced fire hazard
- Faster than traditional methods
- Ability to clean hard to reach areas
- Cleaner work environment



# HYDRO-EXCAVATION NON-DESTRUCTIVE, PRECISION TRENCHING

Evergreen North America field technicians perform hydro excavation services utilizing the finest equipment in the industry. Precise and selective excavation is achieved through the use of high-pressure hydro jet streams, carefully calculated to the appropriate water volume and PSI to safely remove materials without causing unwanted damage to adjacent infrastructure.

## THE HYDRO-EXCAVATION PROCESS

Evergreen North America's customized hydro-vac trucks can simultaneously excavate debris in a self-contained, closed loop system and can be utilized in remote locations with no water hook up.

## THE PERFECT MATCH FOR YOUR SPECIFIC NEEDS

- Exposing Utilities
- Pipeline Services
- Slot Trenching
- Debris Removal and Cleanouts
- Piling Holes
- Culverts
- Cathodic Protection
- Interior Facility Site Work
- Special Drilling Applications
- Pot Holing Services

## THE BENEFITS OF HYDRO-EXCAVATION

- Non-Destructive
- Self-Contained, Closed-Loop System
- Safe and Highly Productive
- Unmatched Precision
- Reduced Liability
- Cost Effective



# EXPLOSIVE CLEANING AND DESLAGGING SERVICES

Evergreen North America offers patented on-line and off-line explosive cleaning and deslagging services. Our staff of licensed industrial explosive technicians - the largest in the world - have performed thousands of successful cleaning jobs in the power generation and manufacturing facilities. Both National and International Emergency Response is available from one of our multiple locations, 24 hours a day.

## ON-LINE VIDEO INSPECTION AND CLEANING

Through controlled detonation portions of the deposits are fractured from surfaces without disturbing the boiler or vessel integrity.

- Super cooled video scope is positioned to look into gas lines
- Pre and post cleaning inspection
- Hidden and hard to reach areas are easily inspected on-line
- Services during temperatures exceeding 2000 degree F
- Camera assisted cleaning ensures unmatched results
- Utilized in boilers, vessels, and confined spaces
- Slag and deposit detection
- Quickly locate hidden tube leaks
- Provides you with digital video documentation
- Multidirectional and zooming capabilities
- Working from outside of the unit, through access doors or viewing ports

## OFF-LINE BOILER AND VESSEL CLEANING - THE EXPLOSIVE LANCE

- No human entry
- Delivers the explosive cleaning charge to the target deposit
- Multiple controlled detonations are performed in grid patterns allowing rapid, safe and thorough removal of deposits
- Boilers
- Kilns
- Silos
- Hoppers
- Process tanks and other large vessels
- Eliminates human exposure to falling debris, height, heat and other confined space risks

## CLEANING WITH DETONATING CORD

- Primarily used for cleaning heavily fouled and tightly spaced boiler sections
- Super-heater
- Reheater
- Economizer
- Formulated delay patterns, powerful energy waves remove hard slag and ash deposits
- Full 360 degrees of coverage
- Creates no byproduct
- Potentially reduce cleaning time



**BEFORE**

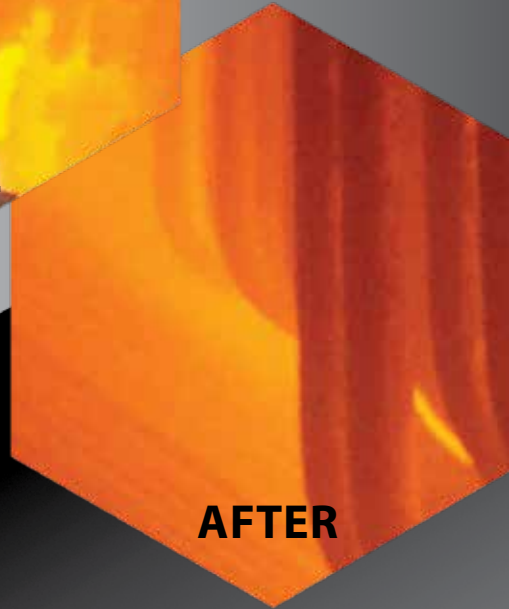

**AFTER**

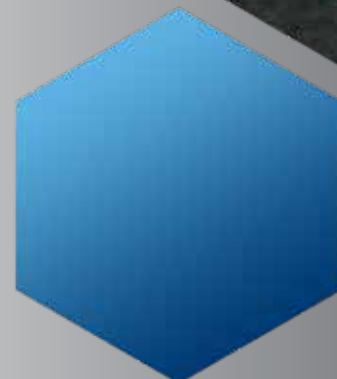
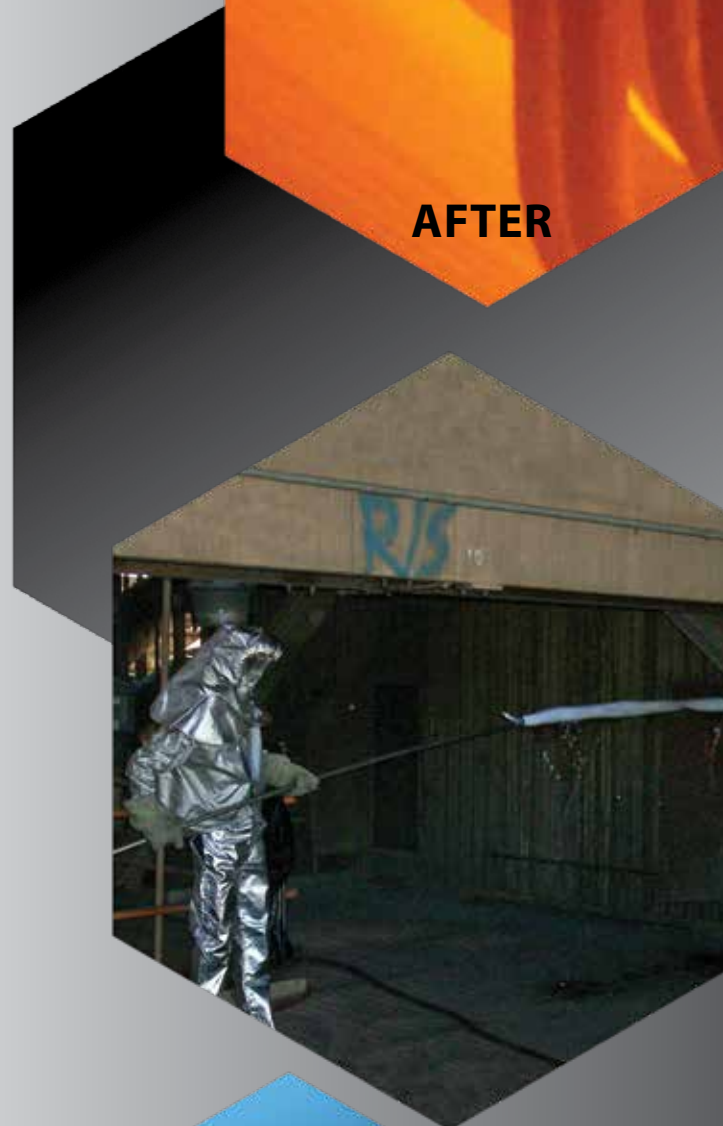

# HYDRO-DEMOLITION

Evergreen North America remains on the leading edge of concrete demolition and resurfacing with the introduction of automated hydro-demolition technology. Safety and efficiency are achieved at an unprecedented level through the use of remote-controlled robots, able to replace older demolition technologies that were often inefficient and prone to causing human fatigue and on site accidents.

## SPEED AND EFFICIENCY

Hydro-demolition is a technology that uses extremely high pressure water jets that are capable of selectively removing concrete, while not disturbing surrounding areas. It is an extremely effective and efficient method of concrete removal. In fact, one hydro-demolition robot can do the work of up to 15 jack hammers.

## POWER AND PRECISION

The variable parameters of our hydro-demolition technology include water pressure, jet size, depth and speed of application. These variables make it possible to demolish and remove concrete in a very precise and controlled way.

## THE MANY BENEFITS OF HYDRO-DEMOLITION

- It is faster and more efficient than conventional mechanical methods of demolition
- Steel reinforcing can be left intact and descaled
- Removes corrosion and mortar paste
- Leaves an exposed, washed and coarse surface on the aggregate, providing an ideal surface for the bonding of new layers
- Dust free
- Reduced noise
- Can precisely and selectively remove damaged or deteriorated concrete, leaving "good" concrete intact
- The absence of vibration reduces unnecessary deterioration or damage to adjacent structures
- Dilutes chloride ion concentrations at bonded surfaces
- Minimizes labor injuries



## ENGINEERED SERVICES

# GEM

 AN EVERGREEN NORTH AMERICA COMPANY

## GEM MOBILE TREATMENT SERVICES

### Turnaround Services - ON POINT Provides Complete Integration of Services for Large Shutdowns

Evergreen North America provides ON POINT Turnaround Services to integrate the details of large, complex shutdowns that must be completed safely, on schedule and on budget. Our proven success record includes numerous refinery-wide shutdowns throughout the US.

ON POINT yields measurable results and eliminates the guess work. Specific Project Management methodologies reduce variation and increase efficiencies. Your KPI's are measured and analyzed for process improvement.

### ONPOINT Turnaround services include:

- Evergreen North America's turnkey cleaning systems
- GEM vapor control and wastewater solutions, pre-planning and on-site project engagement single point of contact for all services, advanced planning and scheduling systems
- Executing QA/QC procedures
- Project-specific performance pricing and guarantees
- Development and integration off task specific safety parameters



## ENGINEERED SERVICES

# GEM

 AN EVERGREEN NORTH AMERICA COMPANY

## GEM MOBILE TREATMENT SERVICES -

### Safe, Fast, Mobile, and Efficient Vapor Control and Wastewater Treatment

GEM offers best-in-class technology and turnkey service to meet the most stringent safety and regulatory requirements for tank degassing and related vapor control activities. Our state of the art mobile vapor combustion units provides high volume operation and efficiency to return tanks to service in a fraction of the time required by other methods.

GEM's service is best in class with over 20 years of leading industry experience in vapor control and wastewater treatment. GEM equipment, processes, and procedures are engineered to meet all local, state, and federal regulatory requirements including EPA, USCG, TCEQ, SCAQMD, and BAAQMD to name a few.

Combined with our chemical cleaning, hydroblasting, tank cleaning, and site services, GEM's vapor control and wastewater treatment gives you a complete, turnkey solution for your industrial safety, regulatory and environmental requirements.

### Benefits

- Safety
- Environmental Compliance
- Responsiveness
- Rapid Turnover
- Cost and Schedule Efficiency
- Turnkey and Engineered Service

### Effective and Efficient

Vapor Combustion and Scrubbing offer the most dependable vapor destruction with the highest processing rates. GEM's vapor combustion unit delivers 99.9+% vapor combustion efficiency, which is documented during processing by onboard instrumentation and data recording systems. GEM also provides comprehensive environmental reporting and consultation to meet the customers' facility permitting requirements.

The GEM vapor control systems operate at industry leading unit flow rates as high as 10,000 SCFM and have a heat capacity as high as 75 MMBTU. Reducing degassing and vapor clearing time not only reduces overall costs, but also minimizes the impact of downtime for tanks and turnaround process units removed from service.





GEM also provides mobile wastewater treatment solutions for a variety of wastewater generation activities. Such activities include process water streams, slop tanks, chemical cleaning waste, tank cleaning rinseate, hydroblasting water, pipeline hydrotest water, containment ponds, oil spill cleanups, fire suppression, and related wastewater generation sources.

GEM treats the wastewater on-site for discharge into existing POTW or NPDES outfalls, on-site wastewater treatment plants or for on-site recycling/reuse.

## Vapor Control Applications

GEM provides a variety of permitted vapor control services for the following petroleum and petrochemical applications:

- Tank Degassing and Refilling Vapor Control
- Sphere and Bullet Degassing
- Pipeline Degassing
- Marine, Railcar, and Truck Loading Vapor Control
- Vacuum Truck and Air Mover Exhaust Vapor Control
- Process Operating Equipment Vapor Control
- Unit Turnaround Vapor Deinventory and Cleaning Vapor Control
- HF Alky Unit Deinventory

## Engineered for Safety

GEM's mobile vapor combustion and scrubbing systems are designed with state-of-the-art safety systems and operated by highly trained and experienced personnel. Our commitment to safety includes in-house equipment design and maintenance programs, extensive pre-project engineering and planning, project specific operating procedures and compliant regulatory permits, recordkeeping and reporting.

## Automated HF Alky De-Inventory

- Concentrations of up to 90% HF can be processed and neutralized if acid storage drum availability is limited
- HF vapor can be vented rapidly using high flow scrubber
- The exothermic heat generation by HF/KOH is safely mitigated with large heat exchangers and cooling water circulation system
- Remote system operation during deinventory safely removes personnel from possible HF exposure and line-of-fire potential



**We have operations in over  
30 locations across the  
United States**



**Evergreen North America**  
INDUSTRIAL SERVICES

**GEM**  
AN EVERGREEN NORTH AMERICA COMPANY



**Corporate Office**  
704 Old Underwood Rd.  
La Porte, TX 77571  
Toll Free: 888-345-8083  
Tel: 281.478.5800  
Fax: 281.478.5004  
[info@enais.com](mailto:info@enais.com)  
[www.enais.com](http://www.enais.com)

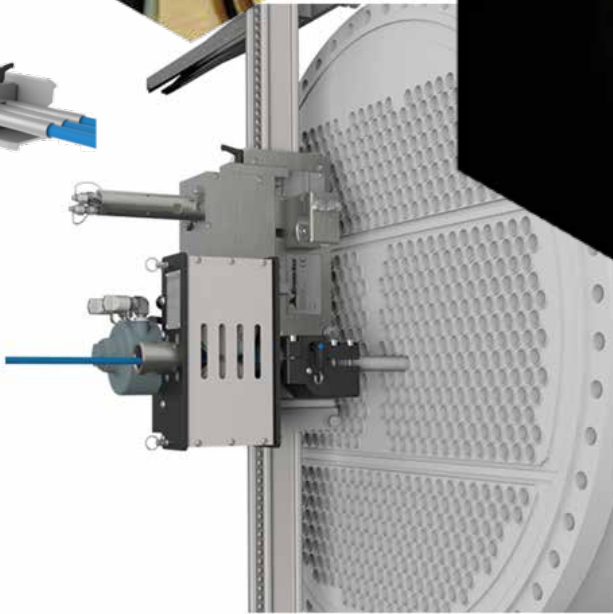
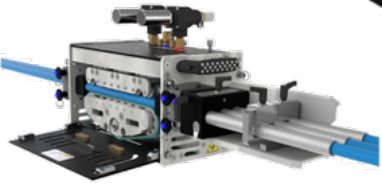

# OUR SERVICES

- Water Blasting
- Hydro-Cutting/Cold Cutting
- Vacuum Truck Services
- Pipeline Cleaning
- Abrasive Blasting and Surface Preparation
- Dry Ice Blasting
- Fugitive Dust Remediation/Foam Cleaning
- Hydro-Excavation/Non-Destructive & Precision Trenching
- Explosive Cleaning & Deslagging
- Hydro Demolition
- Remotely Operated Heat Exchanger Bundle Cleaning Solutions

## ENGINEERED SERVICES

- Tank Degassing and Related Vapor Control Services
- Mobile Wastewater Treatment
- Turnaround Unit Vapor Deinventory
- Marine, Rail, and Truck Loading Vapor Control
- Automated HF Alky De-Inventory
- Chemical Cleaning
- Tank Cleaning



**Evergreen North America**  
INDUSTRIAL SERVICES

Toll Free: 888-345-8083 info@enais.com  
www.enais.com

